



PRODUCT INFORMATION

KWB EASYFIRE

Pellet heating system



KWB

EASYFIRE

PELLET HEATING SYSTEM

2.4 - 38 kW



**EASY
AND CLEAN
HEATING**



PREMIUM QUALITY "MADE IN AUSTRIA"

KWB is the Austrian quality producer of pellet, wood chip and log wood heating systems in the output range from 2.4 to 300 kW. As a pioneer in this sector, we have revolutionized heating with wood. More than 90,000 customers worldwide trust our expertise, including single- and multi-family home owners, agricultural businesses, tour operators, commercial business and utility companies.

KWB is the ideal single-source solution. Our premium products are operationally reliable, and guaranteed Made in Austria. Our assistance commences during your decision-making process and we continue to assist you, together with our trusted partner installation companies, all the way to the installation of your customized comprehensive solution. Our KWB Factory Customer Service and our distribution partners in your vicinity will also be glad to help you at any time!

We provide energy for life!



**PREMIUM QUALITY
"MADE IN AUSTRIA"**



**MORE THAN 90.000
SATISFIED CUSTOMERS**



**NUMEROUS AWARDS FOR THE
FACTORY CUSTOMERS SERVICE**



MADE IN AUSTRIA! AT HOME ALL OVER THE WORLD!

KWB stands for regional and eco-friendly heating with wood. The headquarters of the company is located in the Styrian town of St. Margarethen/Raab (Austria) with subsidiaries in Germany, Italy and France. In 16 additional countries, from Canada to Chile and all the way to Japan, we rely on our strong distribution partners. Together we spread KWB's philosophy all over the world.



KWB EASYFIRE

EASY AND CLEAN HEATING

- ✓ Fits into every heating room thanks to the KWB's modular and easily transportable system
- ✓ Fully automatic filling and ignition
- ✓ No cleaning expenditures for the customer

The KWB Easyfire is the ideal and durable heating system for building renovations or new buildings and is already in use more than 40,000 times worldwide. In the output range between 2.4 and 38 kW, it is installed both in single-family and multi-family homes, for example as a multi-boiler (cascade) system. Thanks to its modular design, it can be easily installed even in tight spaces. The fuel supply and ignition function fully automatically. The heating system basically cleans itself and only the ash bin needs to be emptied between the annually recommended service intervals. Depending on the size of the system, this needs to be done in intervals of up to 2 years. The energy consumption of the pellet heating system is extremely low.



CLEAN COMBUSTION

The cleanEfficiency label indicates lowest emission values, highest efficiency and low energy consumption as well as a perfect alignment of construction and control elements. Modulating buffer operation: The buffer is only charged with as much energy as it requires.

Clean combustion

thanks to the broadband lambda probe. It controls the fuel supply during the combustion process. You benefit from low energy consumption and high operating safety.

Easy installation

due to the integrated return flow temperature boost – which saves you additional installation costs. Optionally with a speed-controlled pump (PWM).

High convenience

thanks to the automatic heat exchanger cleaning – as a result, no cleaning expenditures are required between the annually recommended service intervals every 1,500 nominal load hours.



To find out more about the combustion technology – scan the QR code or visit the KWB YouTube channel.



Low fuel consumption

due to an optimal heat exchange with highly efficient turbulators.

Low energy costs

due to the low energy consumption of the KWB Easyfire pellet heating system – which saves costs.



Lowest emissions

due to a dust separator with cyclone effect. Here, the centrifugal forces are used to push the dust particles that are created during combustion to the outside and collect them in the ash bin.



ONLINE CONTROL

via the KWB Comfort Online platform. Using this platform, the boiler can be easily ignited and controlled remotely from a smartphone, tablet or PC.



CLEAN COMBUSTION TECHNOLOGY

The 40,000 times proven under-feed burner ensures a stable ember bed and clean combustion.



CONVENIENT MOVABLE ASH CONTAINER

Only the ash bin needs to be emptied between the recommended annual service intervals. This occurs after using up approx. 6 tons of pellets conveniently with a movable ash container.



KWB
MODULAR
ASSEMBLY
SYSTEM

CLARITY IN BUILD AND PURPOSE

KWB'S MODULAR AND EASILY TRANSPORTABLE SYSTEM

All KWB systems can be dismantled into several modules, which allows our products to be placed in almost every heating room and easily installed even in tight spaces. We call it the **KWB modular and easily transportable system**.



You can schedule less time

because your technician can move the heating system into the heating room more quickly.



You save money

because your contractor works faster and does not require expensive installation aids.



You preserve and protect your space.

The reduced weight of the individual pieces makes it less likely that you scratch any surfaces of your furnishings.

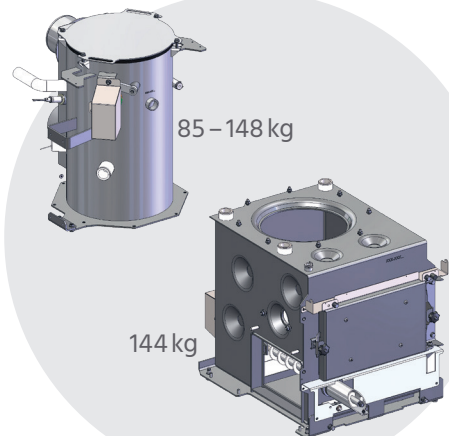

EASY OPERATION

EASY AND FLEXIBLE CONTROL

The KWB Comfort 4 control system offers dual operation options with an intuitive dial and colour touchscreen. It provides information on

- ✓ the ash fill level
- ✓ the storage room fill level
- ✓ the maintenance interval



Furthermore, it is ready for the connection to the **KWB Comfort Online** platform.

ONLINE CONTROL

SECURE REMOTE-CONTROLLED HEATING

Even more convenience and operating safety is guaranteed by the online platform KWB Comfort Online. With this platform, the boiler can be easily remotely ignited, controlled and maintained from your smartphone, tablet or PC. Check on the operating status of your heating, control heating times and temperatures and receive messages and status changes via SMS or email. After taking a holiday, ignite the boiler while on your way home. If desired, you can also provide third parties with individual access to your systems, such as your heating installer or KWB Customer Service.



SOLAR THERMAL ENERGY

THE IDEAL SUPPLEMENT TO BIOMASS HEATING

A solar thermal energy system covers the domestic hot water demand in summer (e.g. for showers) and can support the heating during transition periods and thus reduce heating costs. At best, the boiler remains switched off during the summer and in the transition periods thanks to the sun's heat. A biomass-solar combination ensures full independence from fossil fuels.

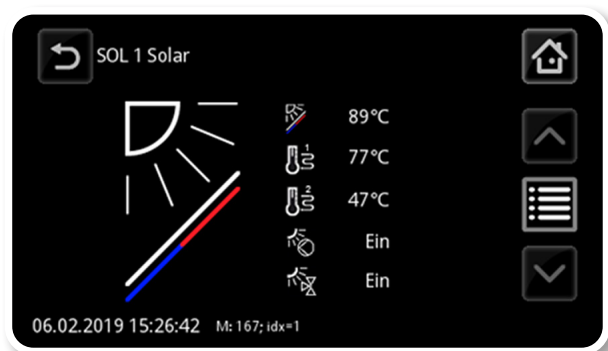

SOLAR CONTROL – INTEGRATED IN THE KWB COMFORT 4 HEATING CONTROL

KWB offers a simple solution for using the power of the sun – also conveniently remotely via KWB Comfort Online. The solar yield can be queried using the integrated solar function of the KWB Comfort 4 control. The wood-based heating system is only started if the sun does not deliver sufficient energy to cover the heat requirements for the room heating or the hot water. The pellet heating system and solar heating work perfectly together.

OUR UNIQUENESS SETS US APART

KWB PELLET STIRRER PLUS

There are many fully automated ways to keep your KWB pellet heating system supplied with fuel. The KWB pellet stirrer plus is a convenient and reliable option that is optimally adjusted to the circumstances on-site.

RELIABLE TECHNOLOGY

Thanks to a conveyor screw on a solid hollow shaft with double bearing.

MAXIMUM SPACE UTILIZATION

thanks to the optimal utilization of the storage volume without inclined floor (with KWB Stirrer Plus).



The KWB Stirrer Plus can be delivered in combination with an elbow screw or a suction conveyor. This ensures the best possible utilization of the storage room volume, does not require an inclined floor and is ideal for quadratic to square storage rooms adjacent to the heating room. The extremely quiet conveyor system is maintenance-free, completely reliable and consumes very little power.

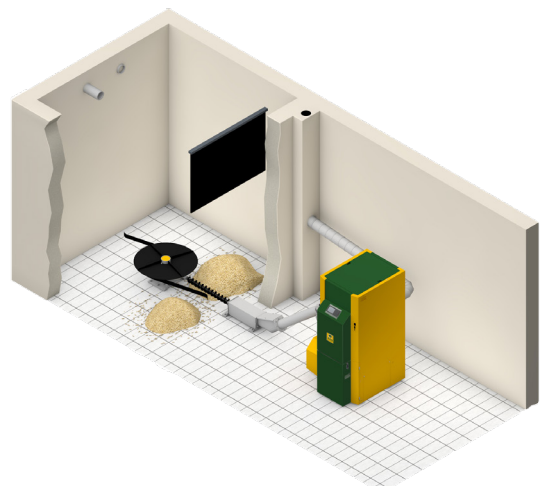

CUSTOMISED SOLUTIONS

KWB CONVEYOR SYSTEMS



KWB PELLET STIRRER PLUS WITH ELBOW SCREW

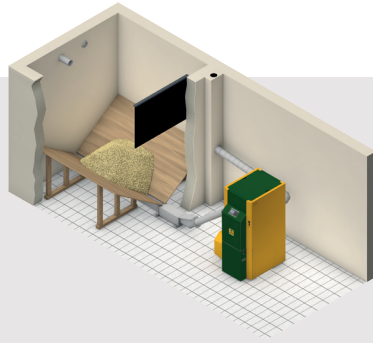

CONVEYOR SCREW WITH ELBOW SCREW

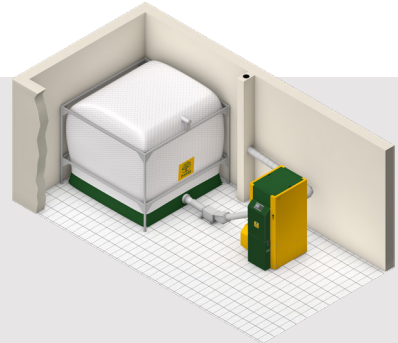

KWB PELLET BIG BAG WITH ELBOW SCREW

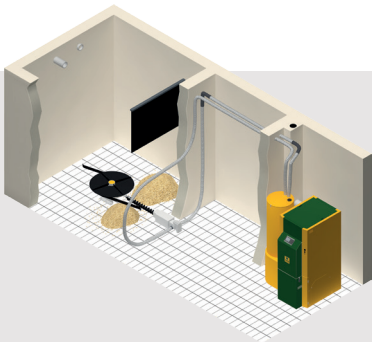

KWB PELLET STIRRER PLUS WITH SUCTION CONVEYOR

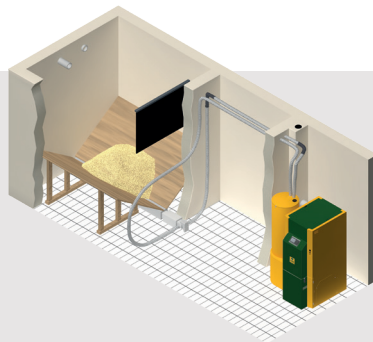

CONVEYOR SCREW WITH SUCTION CONVEYOR

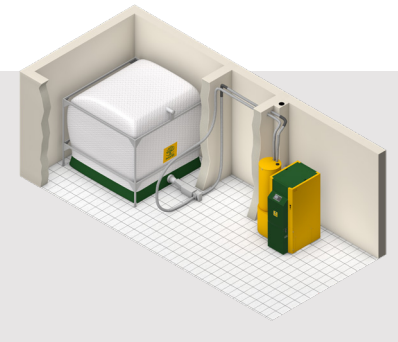

KWB PELLET BIG BAG WITH SUCTION CONVEYOR

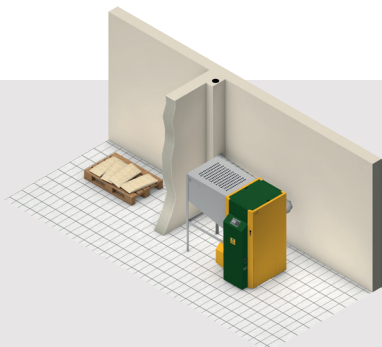

KWB STORAGE CONTAINER 300 L

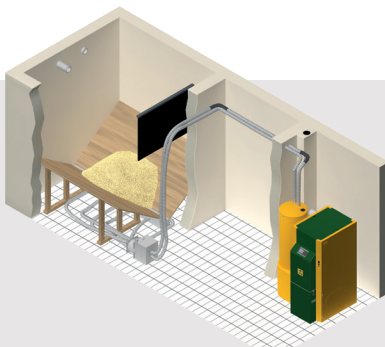

KWB SAMPLE PROBES WITH SUCTION CONVEYOR
(1-POINT SAMPLE PROBE)

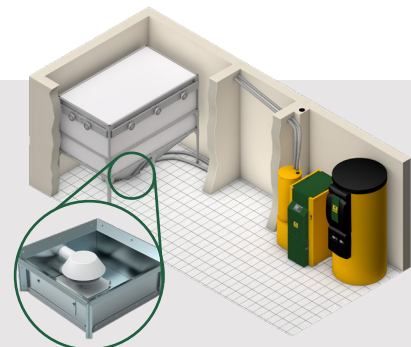

KWB PELLET BOX WITH SUCTION CONVEYOR

CLEAN COMBUSTION

CLEAN EFFICIENCY- TECHNOLOGY

The cleanEfficiency label indicates lowest emission values, highest efficiency and low energy consumption as well as a perfect alignment of construction and control elements.

EMISSION VALUES AT NOMINAL LOAD

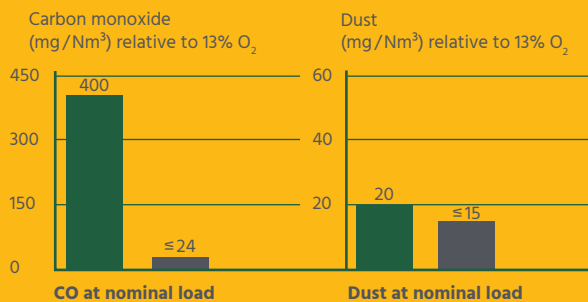

- Legally prescribed emission values, BImSchV Germany, applicable as of 1/1/2015
- Emission values KWB Easyfire with pellets (13% O₂)

Fuel consumption

A KWB Easyfire pellet heating system consumes about 350 kg fuel per 1 kW output.*

* at 1,500 full load hours/year

Quick heat and more efficiency

We recommend using a KWB storage system. This will not only allow you to run your heating cleaner and more efficiently, you will also be able to quickly have heat available when needed.

Recommended storage volume:

Optimally: Buffer volume = 30 litres per kW

Minimum: Buffer volume = 20 litres per kW

Please observe country-specific guidelines and subsidy requirements for the needed storage volume.

DIMENSIONS FOR BOILER TRANSPORT AND PLACEMENT

KWB Easyfire 2	
Conditioned as delivered	600 x 800 mm (W x H)

TECHNICAL DATA

EF2 S / EF2 GS / EF2 V - 27.07.2020	Unit	8	12	15	22	25	30	35	38
Rated power	kW	8,0	12,0	15,0	22,0	25,0	30,0	34,9	38
Partial load	kW	2,4	3,5	4,4	6,4	7,3	8,7	10,1	11,4
Boiler efficiency at rated power	%	92,4	94,0	94,3	95,0	95,2	95,4	95,7	95,3
Boiler efficiency at partial load	%	91,4	89,4	90,0	91,5	92,4	93,8	95,3	94,9
Boiler class according to EN 303-5:2012	-	5	5	5	5	5	5	5	5
EU Energy Label		A+	A+	A+	A+	A+	A+	A+	A+
Exhaust-gas side									
Exhaust-gas connection height boiler side	mm	750	750	860	860	1050	1050	1050	1050
Exhaust-gas pipe diameter	mm	130	130	130	130	150	150	150	150
Ash									
Ash container volume	l	28	28	28	28	28	28	28	28
Electrical system									
Connection		230V, 1~ 50Hz, C13 A	230V, 1~ 50Hz, C13 A	230V, 1~ 50Hz, C13 A	230V, 1~ 50Hz, C13 A	230V, 1~ 50Hz, C13 A	230V, 1~ 50Hz, C13 A	230V, 1~ 50Hz, C13 A	230V, 1~ 50Hz, C13 A
Suction conveyor type EF2 GS									
Max. suction length	m	25	25	25	25	25	25	25	25
Max. suction head	m	5	5	5	5	5	5	5	5
Contents storage container for type EF2 GS	l	42	42	67	67	90	90	90	90
Weights									
Boiler weight EF2 S	kg	326	326	352	352	394	394	394	394

* ... the type approval report is being prepared. Precise value as well as technical data can be downloaded from www.kwbat or www.kwbheizung.de.



Product data sheet with detailed technical data: Scan QR code or download from our website under product pages.

LOW SPACE REQUIREMENTS

The KWB Easyfire pellet heating system can be placed directly at the wall for optimal space utilization.

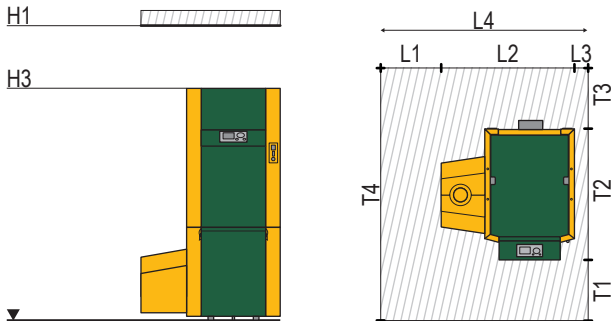

TYPE EF2 S

Heating room size from 2.3m²

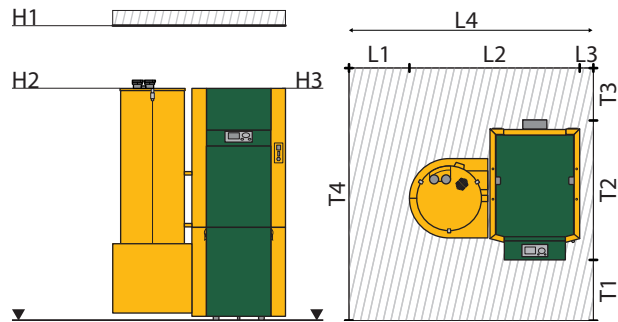

TYPE EF2 GS

Heating room size from 2.6m²

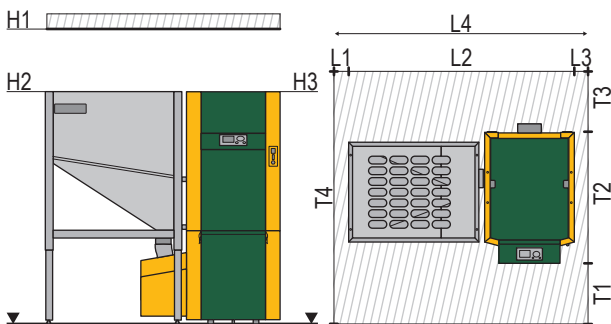

TYPE EF2 S+300

Heating room from 2.8m²

No additional storage room required!

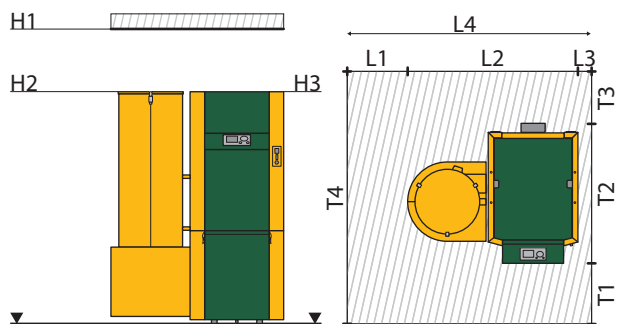

TYPE EF2 V

Heating room from 2.6m²

No additional storage room required!

Position in drawing	EF2 8 – 12 kW				EF2 15 – 22 kW				EF2 25 – 38 kW			
	S	GS	V	S+300	S	GS	V	S+300	S	GS	V	S+300
H1	165	165	165	165	195	195	195	195	230	230	230	230
H2	–	126	146	146	–	146	146	146	–	164	146	146
H3	126	126	146	126	146	146	146	146	164	164	146	164
L1	40	40	40	10	40	40	40	10	40	40	40	10
L2	88	106	106	148	88	106	106	148	88	106	106	148
L3	10	10	10	10	10	10	10	10	10	10	10	10
L4	>138	>156	>156	>168	>138	>156	>156	>168	>138	>156	>156	>168
T1	40	40	40	40	40	40	40	40	40	40	40	40
T2	93	93	93	93	93	93	93	93	93	93	93	93
T3	40	40	40	40	40	40	40	40	40	40	40	40
T4	>167	>167	>167	>167	>167	>167	>167	>167	>167	>167	>167	>167
Exhaust pipe	Ø 13 cm, height = 75 cm				Ø 13 cm, height = 86 cm				Ø 15 cm, height = 105 cm			

S KWB Easyfire type EF2 S: screw conveyor system
 GS KWB Easyfire type EF2 GS: suction conveyor system

V KWB Easyfire type EF2 V: storage container 107 litres
 S+300 KWB Easyfire type EF2 S with storage container 300 litres

Information regarding the hydraulics requirements can be downloaded at www.kwb.at.

All dimensions in cm | Width x Height | Distances stated are minimum!

Note: You will find detailed technical specifications on our website's product pages.



* 2 1 - 2 0 0 2 3 0 3 *

Produktinfo KWB Easyfire 20 EN
Index 0 | 2020-10

Subject to changes as well as
type and printing errors.

CONTACT US

SCOTLAND	+44 1330 826 504	info@originalheating.com
NORTH ENGLAND	+44 1524 784 323	care@sustaburn.co.uk
CENTRAL ENGLAND & WALES	+44 1162 604 050	info@ashwellbiomass.com
SOUTH ENGLAND	+44 1271 372 888	info@optimumheating.co.uk
IRELAND AND NORTHERN IRELAND	+44 2871 353 108	info@originalheating.com
NORWAY	+47 69 22 70 60	post@hr-maskin.no
SWEDEN	+46 498 201750	info@gotfire.se
FINLAND	+358 9 50991	info.technics.fi@algol.fi
ESTLAND	+372 50 96 234	mati@heatpower.ee
JAPAN	+81 3 4405 8088	info@wbenergy.co.jp